

### Summary

Ingress of carbon dioxide into bulk drug substance (BDS) containers that are stored and shipped on dry ice is a serious and often understated problem. Although all bag systems suffer from this phenomenon to some degree due to their thin wall construction and lack of container closure integrity (CCI) testing, standard bottles can also have issues with carbon dioxide ingress.

Bottles are a container of choice for freezing and shipping BDS due to their durability and convenience, compatibility with standard laboratory equipment, shelving and racking, and standard shipping containers. However, not all bottles are tested for CCI, nor does this testing guarantee leak-free performance once frozen. Carbon dioxide can readily enter bottles either through the sidewall material or, most frequently, through leaks in the closure system. Assuring closures are torqued to a validated specification is critical to maintaining CCI.

Fluoropolymer bottles are an excellent choice for BDS processes, as they do not change structurally when frozen. Therefore, most containers manufactured from fluoropolymers maintain seal reliability and sidewall material integrity. The design of the fluoropolymer bottles' closure system is key to ensuring reliable and consistent CCI.



*1,000 mL Purillex® PFA Bottles Being Torqued*

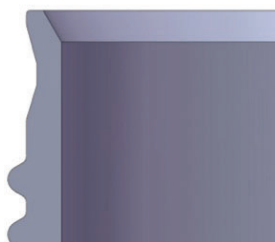

*Purillex® Bottle Neck – Lip Detail*

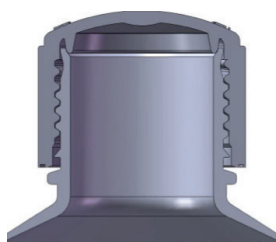

*Purillex® Bottle Neck Closure*

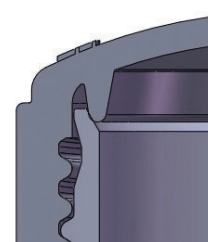

*Purillex® Bottle Closure – Detail*

This technical note outlines two studies performed by a major biopharmaceutical company to determine the closure style and torque specification of Purillex® PFA bottles required to ensure no carbon dioxide ingress during storage and shipping of BDS products on dry ice.

### Test Procedure

#### Materials

- Savillex Purillex PFA bottles, 1,000 mL
- Product formulation buffer solution, pH 7.3
- -80°C cryofreezer
- Bottle transport box
- Dry ice pellets

## Procedure – Study 1

A total of twelve 1,000 mL Purillex PFA bottles were filled with a low volume of formulation buffer solution (100 mL). The initial pH of the solution was measured to be 7.3. Each bottle closure was torqued to the following values using a calibrated torque wrench:

- Bottles 1, 2, 3 were torqued to 40 inch pounds
- Bottles 4, 5, 6 were torqued to 45 inch pounds
- Bottles 7, 8, 9 were torqued to 50 inch pounds
- Bottles 10, 11, 12 were torqued to 55 inch pounds

After torquing, the bottles were frozen in a -80°C cryofreezer for a minimum of 48 hours. At -80°C, the air in the bottle contracts and negative pressure is created, increasing the risk of CO<sub>2</sub> ingress. Bottles were then placed in a transport box to simulate the approved commercial shipping process and covered in dry ice. Dry ice refill was performed as needed over the max transport time allowed (14 days total).

After the 14-day hold period, the pH of each bottle was measured to determine if sufficient carbon dioxide ingress occurred to lower the solution pH.

A pH delta of up to 0.1 is typically inherent to the freezing process for the formulation buffer used during testing.

## Results

While the results were promising, a lower pH was detected in bottle 4, which was torqued to 45 inch pounds. No root cause was identified for this outlier. At the time of testing, it was theorized that the standard closure was not sufficiently robust to ensure a 100% barrier to carbon dioxide ingress during 14 days of exposure.

As a result, a new GL45 bottle closure was designed which includes a floating insert in the cap design. This two-piece floating insert design allows automatic centering and proper alignment of the closure region to ensure a consistent closure seal every time.

Bottle	Closure Torque (inch pounds)	Final pH
1	40	7.3
2	40	7.3
3	40	7.2
4	45	6.8
5	45	7.3
6	45	7.3
7	50	7.3
8	50	7.2
9	50	7.3
10	55	7.2
11	55	7.3
12	55	7.2

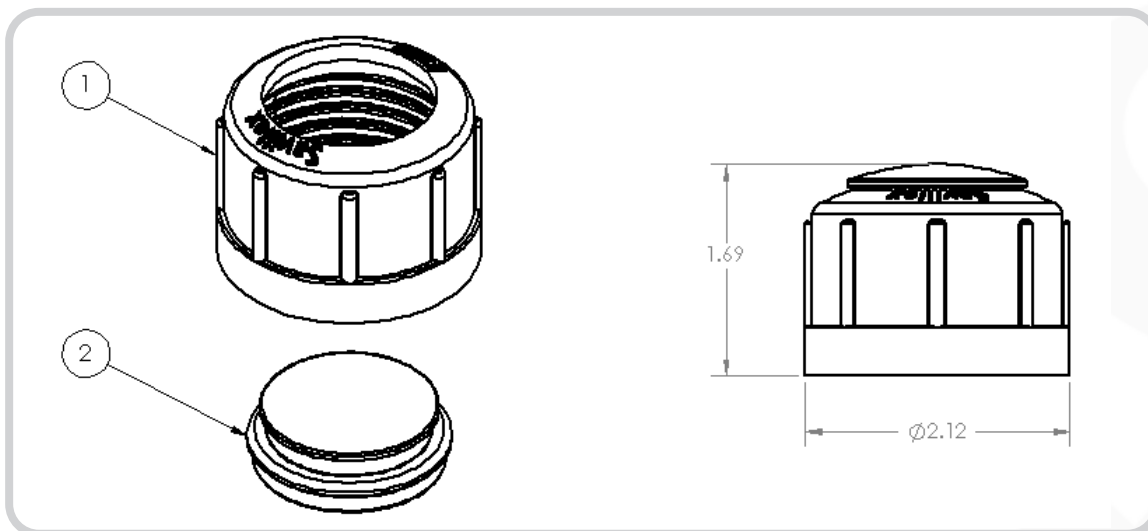

*Two-Piece Bottle Closure with Floating Insert*

## Procedure – Study 2

Eleven 1,000 mL Purillex PFA bottles were filled with a low volume of formulation buffer solution (100 mL). A twelfth bottle was filled to a nominal volume of 700 mL. The initial pH of the solution was measured to be 7.3. The two-piece insert GL45 closure was used on each bottle in this study to determine if it provided a superior seal compared to the standard (one-piece) GL45 closure.

Each bottle closure was torqued to the following values using a calibrated torque wrench:

- Bottles 1, 2, 3 were torqued to 40 inch pounds
- Bottles 4, 5, 6 were torqued to 45 inch pounds
- Bottles 7, 8, 9 were torqued to 50 inch pounds
- Bottles 10, 11, 12 were torqued to 45 inch pounds

Bottle 10 used a closure which was pierced to produce an ingress point as a positive control. Bottle 11 was over-wrapped with a polyester film bag laminated with aluminum foil and LDPE inside as a negative control.

The bottles were then frozen in a -80°C cryofreezer for a minimum of 24 hours. Next, the bottles were placed in a transport box to simulate the approved commercial shipping process and covered in dry ice. Dry ice refill was performed as needed over the max transport time allowed (14 days total).

After the 14-day hold period, the pH of each bottle was measured to determine if sufficient carbon dioxide ingress occurred to lower the solution pH.

## Results

All test bottles passed the criteria of a pH delta of no more than 0.1 units after the 14-day hold period. No difference was detected between the test bottles and over-wrapped negative control. The pH of the positive control dropped 1.4 units, indicating carbon dioxide ingress.

## Conclusion

Results indicate that a standard bottle closure system may not be sufficient to ensure there is no carbon dioxide ingress during the simulated 14-day dry ice shipping process. Therefore, standard bottle closures are not recommended to be used for long term exposure to dry ice.

Bottle	Volume	Closure Torque (inch pounds)	Final pH
1	100 mL	40	7.2
2	100 mL	40	7.2
3	100 mL	40	7.2
4	100 mL	45	7.2
5	100 mL	45	7.2
6	100 mL	45	7.2
7	100 mL	50	7.2
8	100 mL	50	7.2
9	100 mL	50	7.2
10 (pierced closure)	100 mL	45	5.8
11 (overwrapped bottle)	100 mL	45	7.2
12	700 mL	45	7.3

Test results from the two-piece insert closure testing indicate that this closure system is sufficient to ensure there is no carbon dioxide ingress during the simulated 14-day dry ice shipping process. It is recommended that the Savillex two-piece insert closure be used whenever product bottles are shipped on dry ice.



Savillex

10321 West 70th St. | Eden Prairie, MN 55344-3446 USA | Phone: 952.935.4100

Email: [info@savillex.com](mailto:info@savillex.com) | [www.savillex.com](http://www.savillex.com)

TN031 010721