

New Electromagnetic Flowmetering Technology for Single Use Biopharmaceutical Processes

By Thomas Roemer, Business Development Manager and Christine Perfetti, Senior Marketing Manager, KROHNE

The biopharmaceutical industry is moving towards using disposable single-use technology for manufacturing products using living organisms (proteins), including vaccines and antibodies. Manufacturers now want to dispose of virtually everything that comes in contact with the cell culture material rather than cleaning and reusing products in the bioprocessing process. Single-use technologies were initially employed primarily for batch processes that used scales for mass balancing/process control. The new trend is to use single use technologies for continuous manufacturing processing. This requires continuous flow measurement.

In response to this market demand, KROHNE developed a new electromagnetic flow metering technology that is particularly adapted to in-line flow measurement in such downstream processes as normal filtration, tangential flow filtration, chromatography, buffer or media preparation, and general monitoring and control of fluid transfer in the manufacturing of antibodies, anticancer drugs, or vaccines.

Electromagnetic flowmeters subject conductive liquids to alternating or pulsating DC magnetic fields. Electrodes on either side of the pipe wall pick up the induced voltage following Faraday's Law, which is proportional to fluid velocity. Measurement is independent of density, temperature, viscosity and pressure and is extremely accurate, with a wide flow measurement range. They also have no moving parts or obstructions in the flow path. However, the measured liquid must be conductive for proper operation. The new technology, the FLEXMAG 4050 C, is composed of a compact transmitter and a biocompatible single-use disposable flow tube with single barb fitting that can be removed after use. It is designed to be part of single use OEM machines. The transmitter is installed in the machine and connected to the control system while the FLEXMAG flow tube gets assembled and integrated into a single use process flow kit.

Figure 1 shows the flowmeter.



Fig 1. FLEXMAG 4050 C

The device transmitter generates the magnetic field for the measuring tube and is responsible for the signal conversion. It also includes the holder for the disposable flow tubes. The same transmitter can accommodate two different flow tubes sizes – either 3/8 and 1/2-inch or 3/4 and 1-inch. This gives end users the flexibility to handle two different flow ranges by simply exchanging the tube – without having to re-calibrate. The new technology is compact and can fit into compact machines. The flowmeter has inaccuracy of only 1 percent of the measuring value.

The new flowmeter flow tube uses a single barb fitting that meets biopharmaceutical requirements for adaptation to single use systems and is manufactured according to FDA/USP Class VI and ISO 10993, in an ISO 13485 certified site within an ISO 7 clean room environment. The tube's full-bore construction is designed for minimal hold-up volume without obstruction, and the single barb fitting is suitable for braided as well as non-braided hoses. The single-use flow tubes are gamma sterilizable at 25...40 kGy irradiation and are made with animal free compounds. The disposable single-use flow tubes are packed in individual double sealed double layered polyamide/polyethylene pouches.

Tested and qualified for use

The new flowmeter has been tested and qualified for use with Quattroflow Single-Use pumps, which are equipped with a single use pump chamber.

KROHNE tested the accuracy and response time of the FLEXMAG 4050 C on a Quattroflow QF 1200 quaternary diaphragm pump. In addition to the pump and flowmeter, the test bench included a reference (non single-use) electromagnetic flowmeter meter (OPTIFLUX 5300) and a Quattroflow proportional-integral-derivative (PID) controller (QFPID01).

The pump's values were set and displayed on the PID screen. The analog output of the FLEXMAG 4050 C was connected to the PID controller's 4-20 mA input. The flowmeter value was displayed on the PID screen and compared to the pump's pre-set value. The pulse output of the FLEXMAG 4050 C was reported on the PC, along with information on the reference meter.

Figure 2 shows a graphic representation of the test set up:

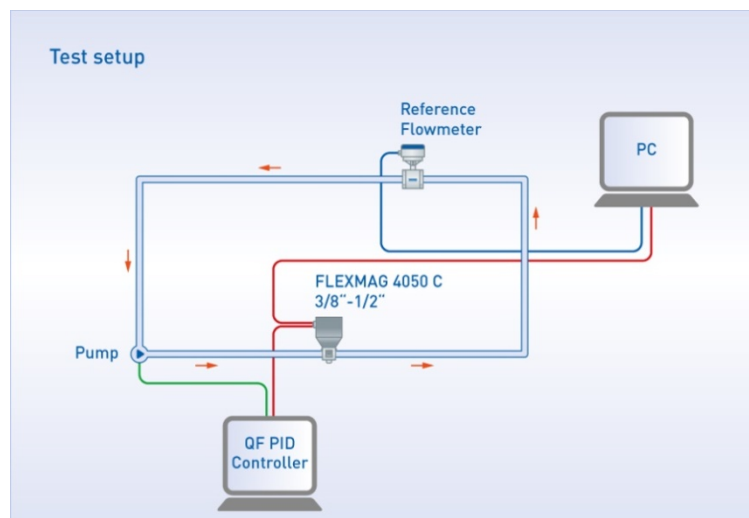

Fig 2. Test setup

The test protocols used included a flowrate slowdown and increase of 1.5 liters per minute (l/min) every minute, using a 3/8-inch tube (with a flow rate of 0.5 l/min-to 14 l/min) and a 1/2-inch tube (extended range 0.02 l/min -20 l/min). The test also included inducing a rapid flow change.

Table 2 provides an example of set point values with the 3/8-inch tube.

Table 2 – Setpoint values with 3/8-inch tube		
L/min	min:sec	s
14	00:00	0
12.5	00:40	40
10	01:30	90
7.5	02:25	145
5	03:10	190
2.5	04:00	240
1.25	04:45	285
0.5	05:45	345
0.25	06:48	408
0.1	07:50	470
0.05	09:10	550

The tests showed that the new flowmeter followed the pump flow change. Stabilizing after only a few seconds at the set up flow value, the flowmeter perfectly controlled pump behavior. **Figure 3** compares the results of the reference meter with those of the new single use electromagnetic meter.

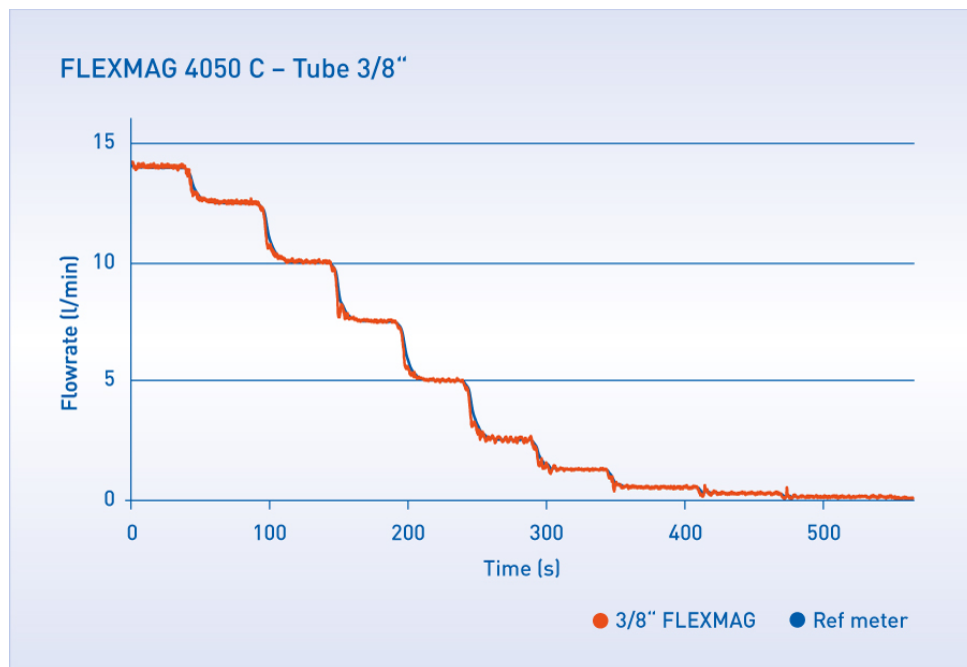

Fig 3. Test results – 3/8-inch tube

Since the reference meter has no time constant, the slope of the blue line shows the PID controller's time constant directly. The FLEXMAG 4050 C line (orange) is very smooth, due to the flowmeter's very low electrical noise. The device's 3-second time constant is perfectly adapted for this velocity of flow changes. The orange line is hardly visible due to the new meter's accuracy compared to the reference meter, from high to low flow measurements. The flowmeter controlled the pumps over its complete range, from 20 l/min down to 0.02 l/min. The values remain accurate even at very low flow.

The tests show that the flowmeter signal is very stable and accurate. This enables the quaternary diaphragm pump to produce an accurate flow, and ensures the PID controller can maintain and change flow speeds fast and accurately.

In addition, any pulsation from the Quattroflow QF 1200 quaternary diaphragm pump had no impact on the flow measurement. Also, when the flow was suddenly switched from minimum to maximum flow, the flowmeter did not experience any disturbance or deviation.

The KROHNE FLEXMAG 4050 C could control the quaternary diaphragm pump with extreme preciseness, whatever flow shapes, rise, drop, or picks it had to handle.

Accurate and stable volumetric flow measurement

The new single-use electromagnetic flowmeter provides a completely stable, direct, and accurate volumetric flow measurement, unaffected by fluid properties such as color or density. It has the technical accuracy for downstream processes handled by typical single use pumps. Thanks to its compact size, the FLEXMAG 4050 C is easy to integrate into single use systems. The FLEXMAG 4050 C, hence offers the best compromise between accuracy, cost and compact size available on the market.

KROHNE, INC

Peabody, March 8th 2018

References:

- [¹] Optimizing Unit Operations In Biopharmaceutical Manufacturing, https://www.psgdover.com/assets/quattroflow/downloads/white-papers/Quattroflow_whitepaper_Unit-Operations_Apr17.pdf, retrieved 3/6/2018.
- [²] Liquid Flowmeters for Bioprocessing, An overview of the diverse technologies available, <https://www.flowcontrolnetwork.com/liquid-flowmeters-for-bioprocessing/>, retrieved 1/29/18.
- [³] Review of industrial processing flowmeters, Understanding flowmeters and their pros and cons, By Ron DiGiacomo, ABB Measurement Products, <http://docplayer.net/17820382-Abb-flowmeters-review-of-industrial-processing-flowmeters.html>, retrieved 3/6/2018.